

PR(C)V減壓閥

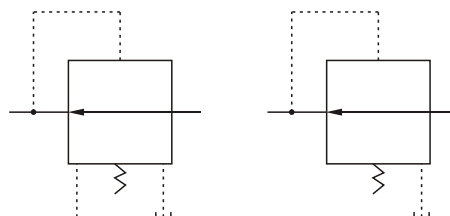

PRV液壓符號:



PRCV液壓符號:

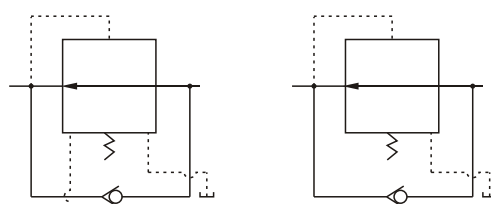

特 性:

- PRV減壓閥是支回路用來設定低於主回路壓力的控制閥，同時還能夠通過遠程控制口，進行遠程控制。
- PRCV單向減壓閥是減壓閥並聯單向閥，使之起到單向減壓的作用。

■ 規格說明

型 號	最高使用壓力 (bar)	額定流量 (L/min)	安裝螺絲	重 量 (kg)	
PRV-G03	250	50	4-M10x55L	4.8	
PRV-T03			--	4.6	
PRCV-G03			4-M10x85L	5.5	
PRCV-T03			--	4.8	
PRV-G06		125	125	4-M10x55L	6.9
PRV-T06				--	7.4
PRCV-G06				4-M10x85L	8.5
PRCV-T06				--	8.5
PRV-G10		250	250	6-M10x65L	12
PRV-T10				--	13.4
PRCV-G10				6-M10x105L	14.5
PRCV-T10				--	15.5

■ 型號說明

PRCV - G 03 - 1 - 10

① ② ③ ④ ⑤

① 閥代號:
PRV: 減壓閥
PRCV: 單向減壓閥

② 安裝形式:
G: 板式安裝
T: 管式安裝

③ 公稱口徑:
03: 10mm
06: 20mm
10: 32mm

④ 壓力調節範圍(bar):
1: 7-70
2: 35-140
3: 70-250

⑤ 設計型號

■ 反向自由流壓降

測試條件: 黏度:35cSt 溫度:50℃

● PRCV-※03

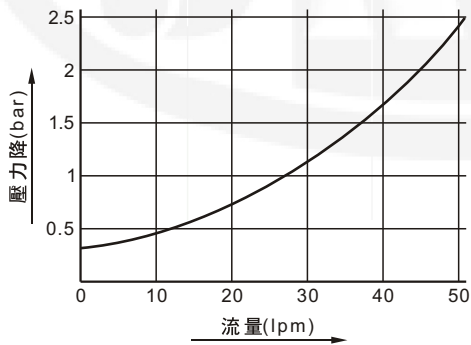

● PRCV-※06

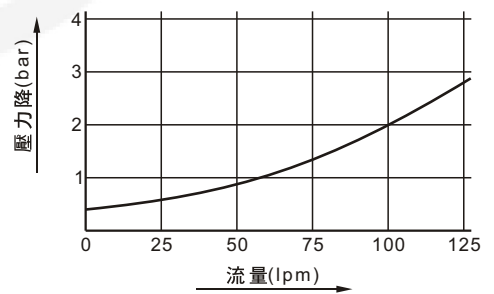

● PRCV-※10

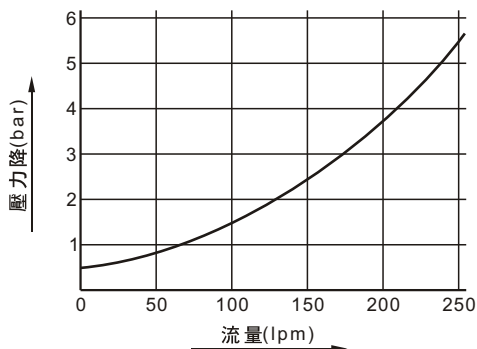

■ 尺寸圖

● PRV-G03/06/10

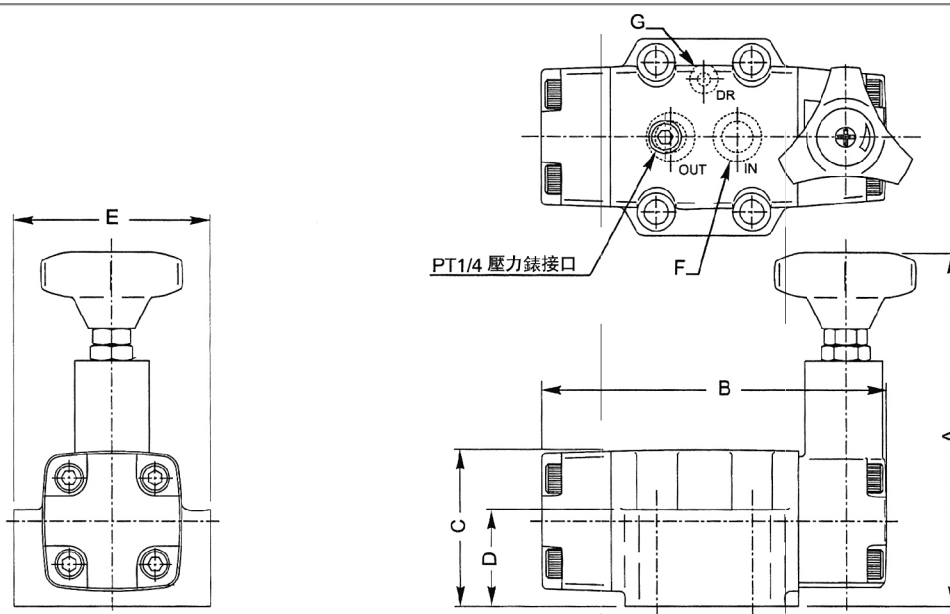

型號	A	B	C	D	E	F	G
PRV-G03	164	158	70	42	87	P18	P10
PRV-G06	170	185	83	42	100	P28	P10
PRV-G10	174	220	94	48	120	P40	P10

● PRV-T03/06/10

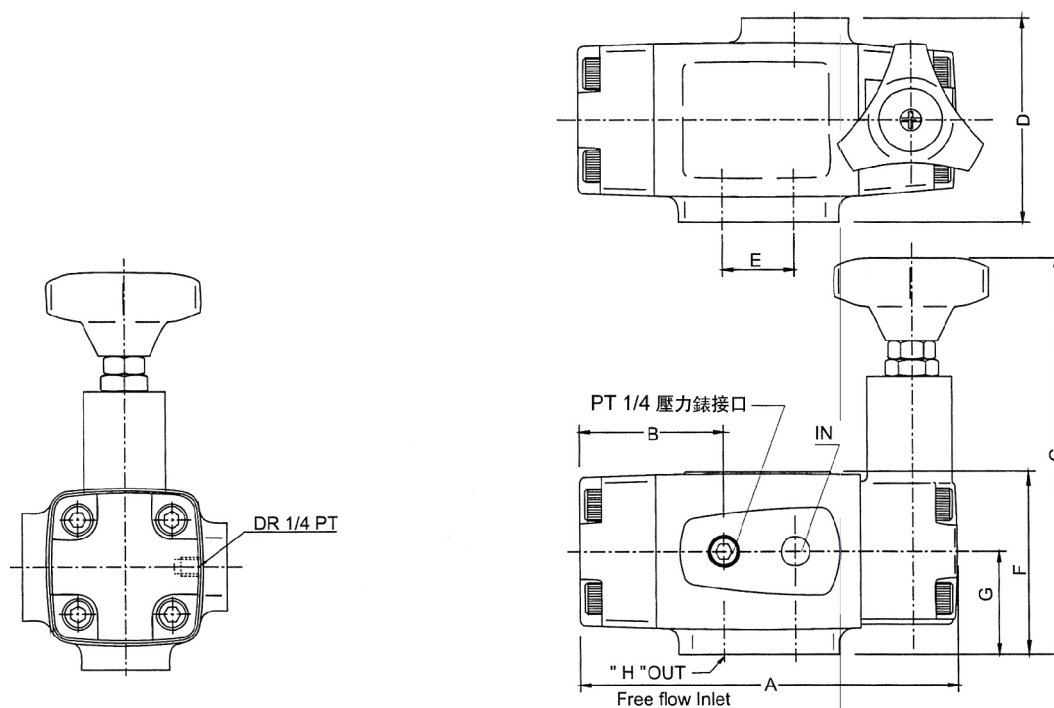

型號	A	B	C	D	E	F	G	H
PRV-T03	158	57	162	82	28	74	40.5	PT3/8
PRV-T06	184	66	161	87	34.5	96	48	PT3/4
PRV-T10	221	75	178	132	48	109	63.5	PT1-1/4

■ 尺寸圖

● PRCV-G03/06/10

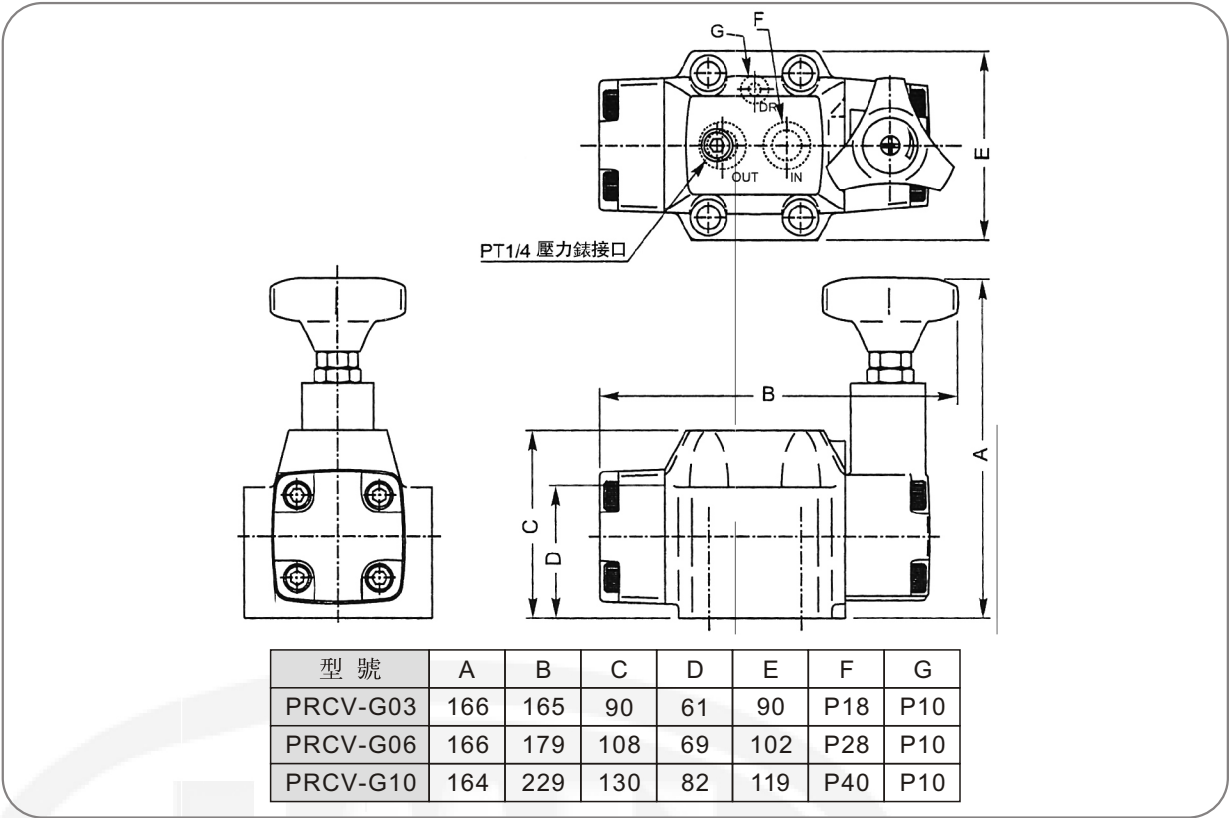

● PRCV-T03/06/10

